

# OPERATOR'S MANUAL



OCT  
1970



# M60

## MACHINE GUN

# SAFETY INFO.



## \* WARNING \*

- KEEP YOUR M60 AIMED AT ONLY WHAT YOU WANT SHOT -- DOWN RANGE.
- CLEAR THE GUN WHENEVER YOU DO NOT INTEND TO FIRE.
- ALWAYS EYEBALL THE CHAMBER AFTER CLEARING THE GUN.
- CHANGE HOT BARRELS ONLY WITH YOUR ASBESTOS MITTEN.

**MUST  
HAVE**

**WITH EACH GUN & TRIPOD!**



LUBRICATING OIL -  
LSA - 9150-889-3522

HANDLE ASSY. -  
1005-793-6761



(5) ROD SECTIONS - 1005-726-6109

(4) BORE BRUSH - 1005-556-4174

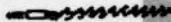

SWAB HOLDER SECTION -  
1005-726-6110



RECEIVER BRUSH -  
1005-350-4100

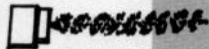

CHAMBER BRUSH -  
1005-690-3115



SCREWDRIVER &  
REAMER WRENCH -  
5120-461-1075



**EMS**

TM 9-1005-224-10

# OPERATING YOUR M60



# MORE on HOW TO PUT IT TOGETHER

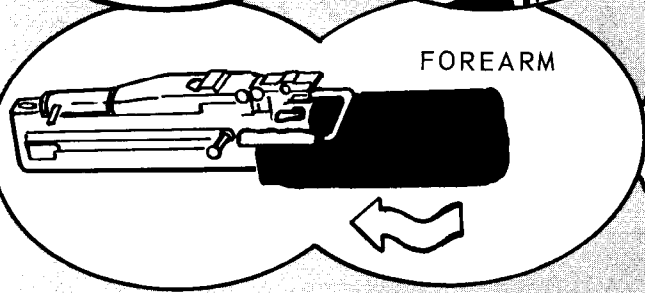
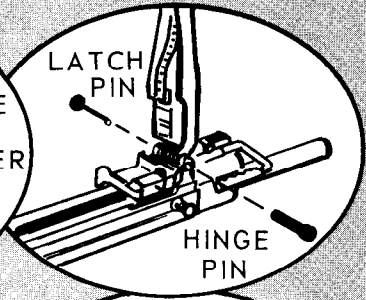
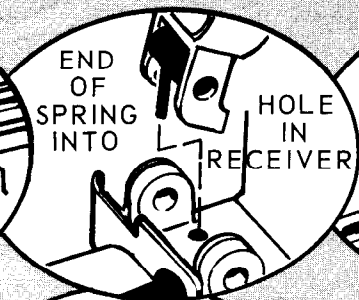
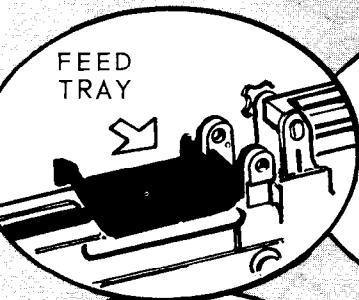

**STILL MORE**

# FINAL WORD on PUTTING IT BACK TOGETHER

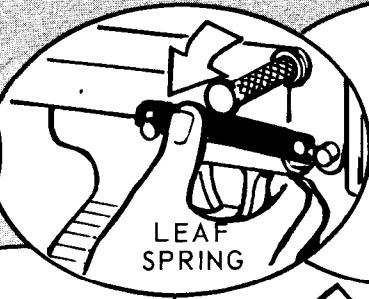
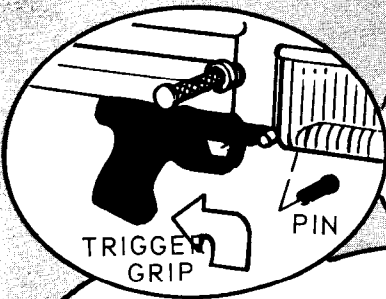

then -  
COCK it  
and  
SAFE it

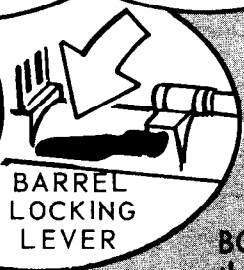
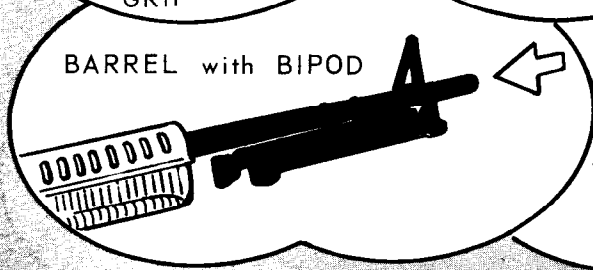

Put on  
"FIRE"  
and EASE  
BOLT FORWARD  
then, SAFE IT.

PARTS LEFT OVER ? ..OH OH..DOUBLE CHECK and TRY IT AGAIN !!

# "WHERE TO FIND IT"

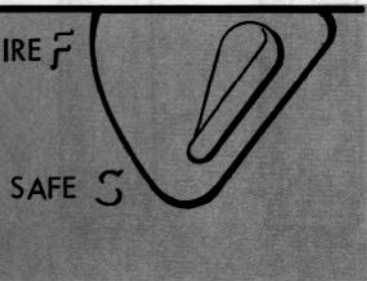
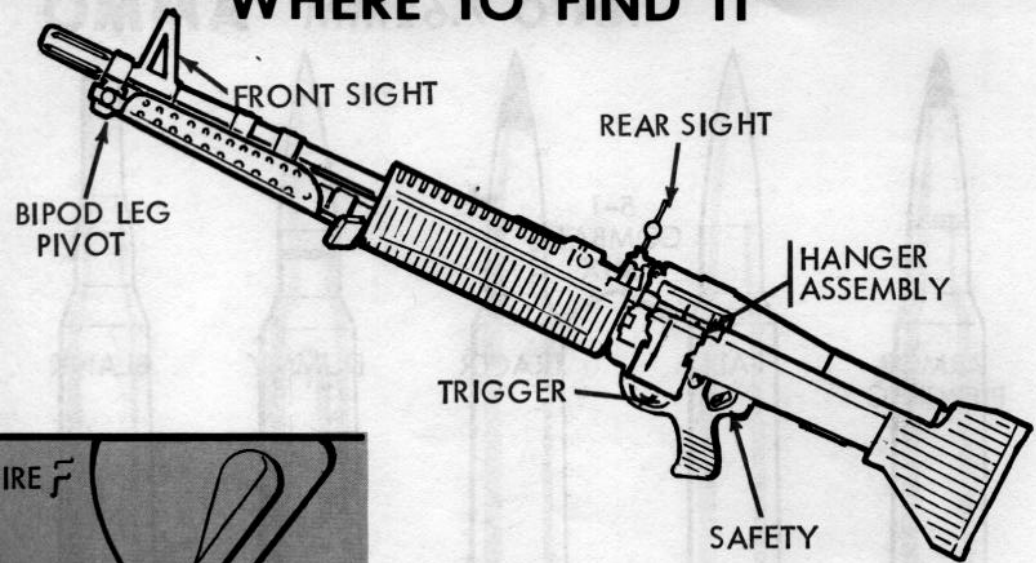

# NATO 7.62MM **AMMO**

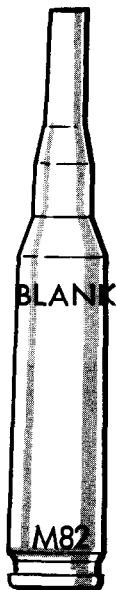
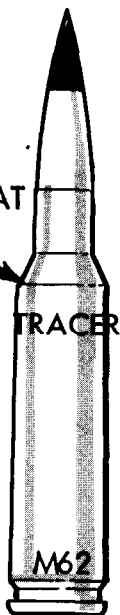
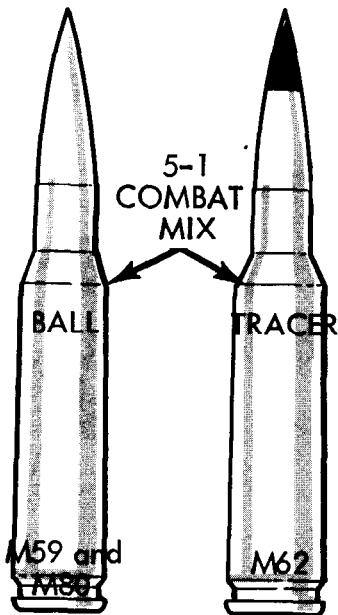



# LOADING

- PULL BOLT to rear
- SAFE the gun
- OPEN the cover
- EYEBALL the chamber
- LOAD ammo on feed tray

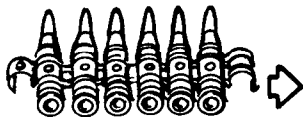
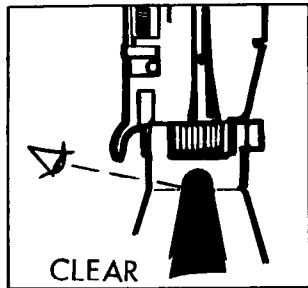

OPEN SIDE of  
Links DOWN

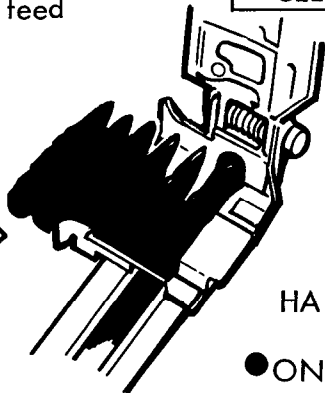

- CLOSE COVER
- RETURN COCKING HANDLE FORWARD
- ON "FIRE" and GO!

# UNLOADING & CLEARING

✓ PULL BOLT

✓ SAFE

✓ OPEN THE COVER

✓ REMOVE THE AMMO

✓ EYEBALL THE CHAMBER

✓ EMPTY A-OK

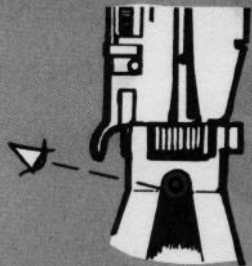

**OH OH!**

\* **ROUND IN CHAMBER**

● CLOSE COVER, AIM, FIRE -

IF IT FIRED AND EXTRACTED, YOU'RE CLEAR.

# LOADING

- PULL BOLT to rear
- SAFE the gun
- OPEN the cover
- EYEBALL the chamber
- LOAD ammo on feed tray

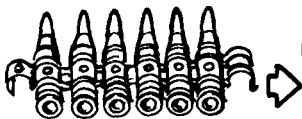

OPEN SIDE of  
Links DOWN

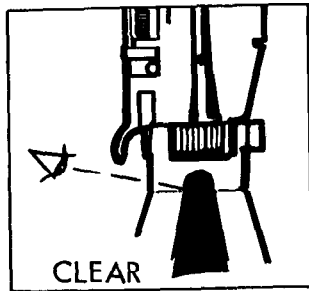
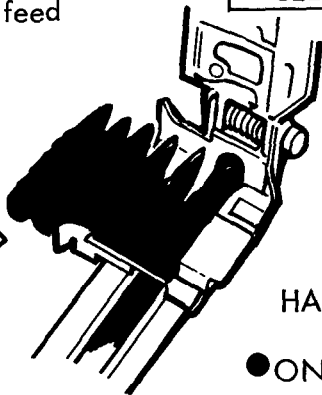

- CLOSE COVER
- RETURN COCKING HANDLE FORWARD
- ON "FIRE" and GO!

# IF it didn't extract You got a STUCK CARTRIDGE and TROUBLE

- TAKE THE BARREL OUT
- INSERT CLEANING ROD (BARE END) AND GENTLY TAP OUT CARTRIDGE OR CASE.

## ★ RUPTURED CARTRIDGE

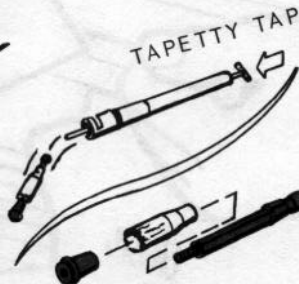
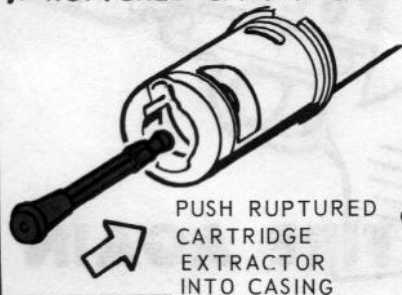

- PUT BARREL BACK
- CLOSE COVER
- HOLD COCKING HANDLE, PULL TRIGGER— AND EASE BOLT FORWARD

★ CLEARED

IF THE GUN DOESN'T FIRE

... TAKE

IMMEDIATE  
ACTION

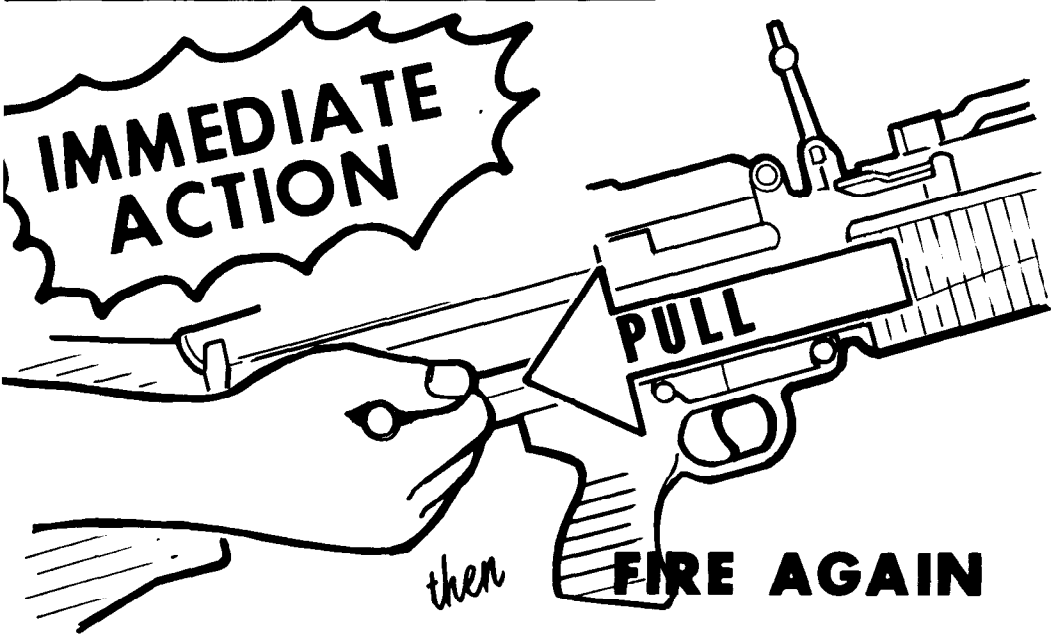

*then*

**FIRE AGAIN**

**IF IMMEDIATE ACTION DOESN'T CURE  
YOUR PROBLEM** *CHECK*



lube?

**LSA it!**

dirty?

**clean it!**

put together wrong? **fix it!**

barrel trouble?

**change it!**

# "BABY IT" BUDDY

Go over your M60 carefully,  
**LÔÔK** for... **RUST, DENTS,**  
**DAMAGE, DIRT** and **CRAP**

Make sure it's in **TOPNOTCH**  
shape **NOW**

Your **LIFE DEPENDS ON IT!**

# FIELD STRIP • BARREL with BIPOD

CHARGE  
it!  
SAFE  
it!

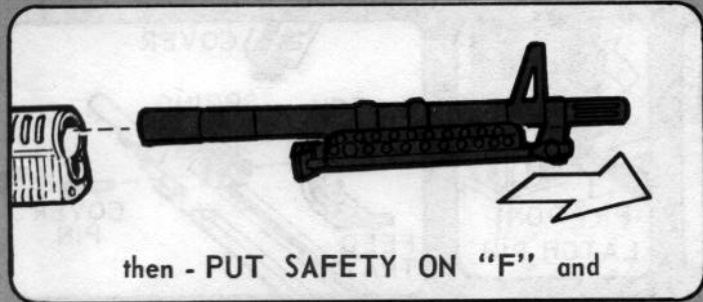
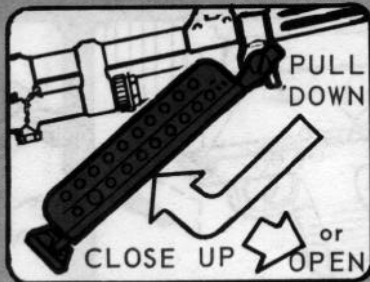



# MORE FIELD STRIP

TRIGGER GROUP\*GUNSTOCK\*FOREARM\*  
COVER and FEED TRAY

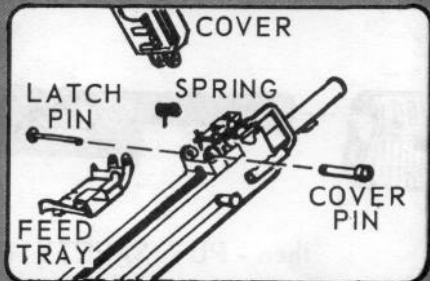
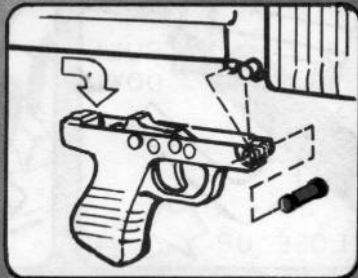

BUFFER \* YOKE \* DRIVING SPRING & GUIDE \* BOLT \* OPERATING ROD

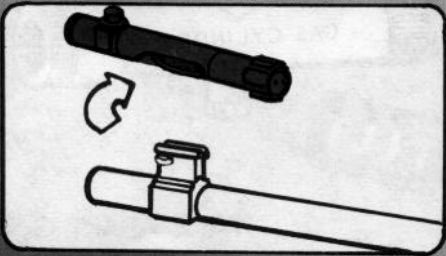
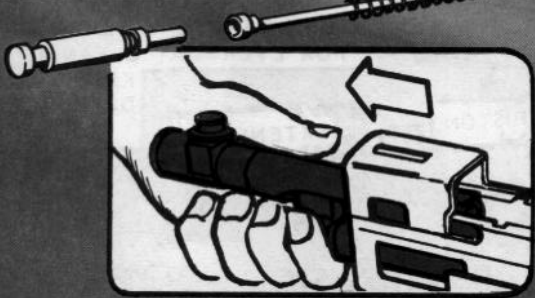
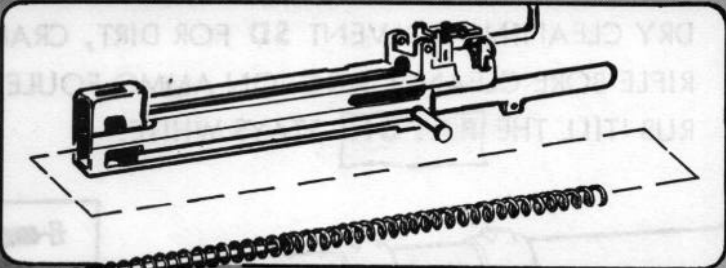

BINGO!

# WHITE GLOVE your M60 & M122

DRY CLEANING SOLVENT **SD** FOR DIRT, CRAP, GRIT.  
RIFLE BORE CLEANER **RBC** ON AMMO FOULED AREAS.  
RUB 'TILL THE **PATCH** STAYS WHITE.

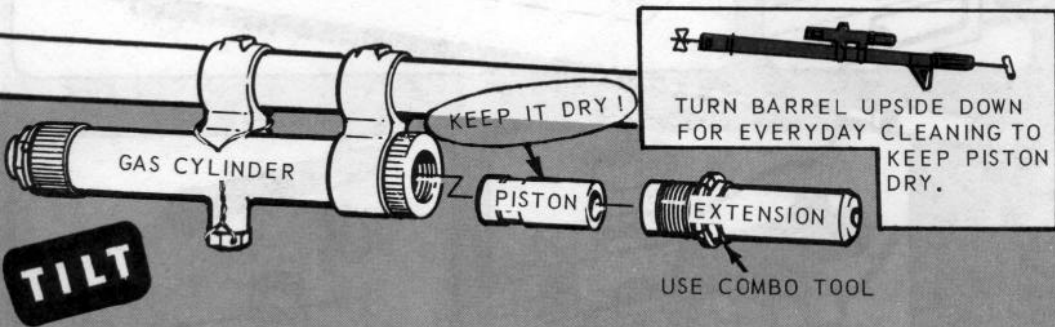

TAKE APART ONLY WHEN THE PISTON WON'T CLICK  
WHEN BARRELS TILTED END FOR END.

# CLEANING TRIGGER GRIP & BOLT

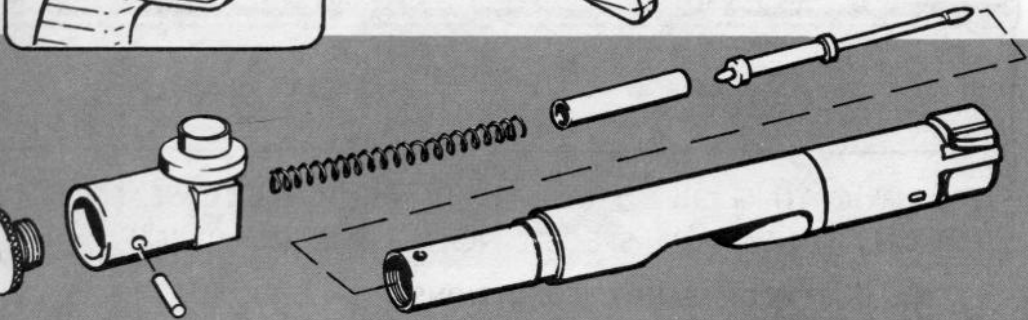
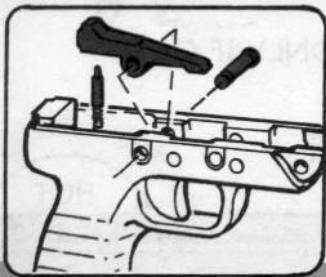

# LUBE GUIDE

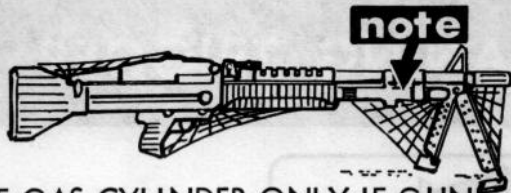

LUBE GAS CYLINDER ONLY IF GUN  
IS TO BE INACTIVE !

## type of CLIMATE

COLD

0° F

HOT

**LAW**

\* **PL** SPECIAL

**L**UBRICATING OIL **S**EMI - FLUID, **A**UTOMATIC WEAPONS  
ALL THE WAY (IN SPECIAL NOOKS AND CRANNIES).

\* DUSTY OR SANDY CONDITIONS?  
THEN, A LITTLE DAB'LL DO IT!

# SPECIAL NOOKS AND CRANNIES

for

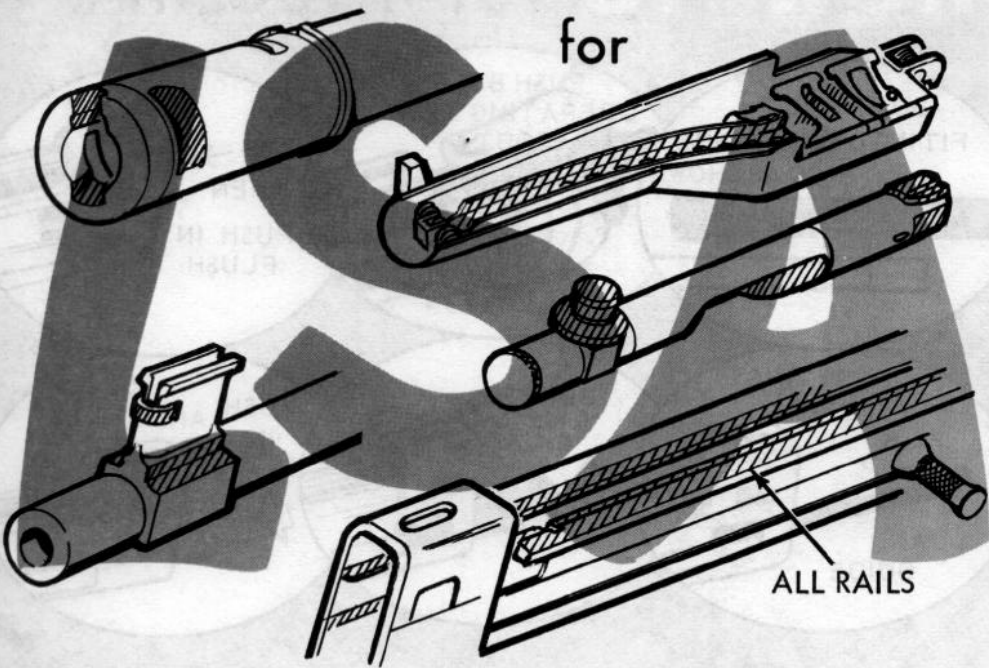

ALL RAILS

# HOW TO PUT IT TOGETHER

BOLT MUST  
FIT INTO OPERATING  
ROD AS SHOWN

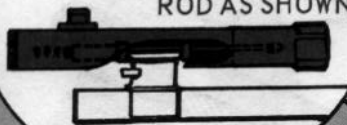

PUSH BOLT &  
OPERATING ROD  
ABOUT



HALFWAY IN

THEN  
PUSH IN  
FLUSH



OPERATING  
SPRING



AND  
GUIDE

BUFFER

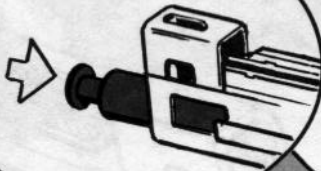

PUSH IN  
SEAT  
AND YOKE

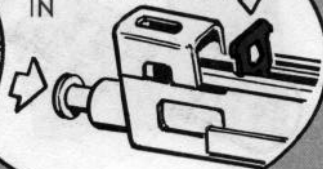

# GUARANTEE

IF YOU GO BY ALL THE INSTRUCTIONS IN THIS BOOK, WE GUARANTEE YOUR MACHINE GUN TO SHOOT, AND SHOOT AND SHOOT.

IF YOU'VE DONE YOUR PART AND IT STOPS SHOOTING, TAKE YOUR MACHINE GUN TO YOUR SERGEANT AND HE'LL GET THE ORGANIZATIONAL MAINTENANCE MAN TO RESTORE THE MERCHANDISE TO FULL FIREPOWER FOR YOU.

***It's YOUR machine gun, Soldier,  
keep it shootin'!***

This new Department of the Army manual supersedes old TM 9-1005-224-10, with changes, dated 20 Nov. '67.



# WHAT IS THE M60?



LOOKIE HERE ! A MACHINE GUN, M60, 7.62-mm.  
MAN, THIS BABY'S EVEN GOT FIXED HEADSPACE -SO-  
YOU CAN CHANGE THOSE BARRELS IN A BIG HURRY.

WEIGHT 23 pounds

RATE OF FIRE

CYCLIC 550 rounds per minute

SUSTAINED\* 100

RAPID\* 200

BANDOLEER CAPACITY 100 rounds

\* YOU GET THESE RATES THROUGH PRACTICE  
AND A TRICKY TRIGGER FINGER !

# SIGHTING IN



MAXIMUM EFFECTIVE RANGE IS AS FAR AS YOU CAN SEE TO ADJUST FIRE ACCURATELY ON TARGET.

SO .. CHECK YOUR SIGHT TO SEE THAT IT WORKS -- NO DAMAGE ALLOWED

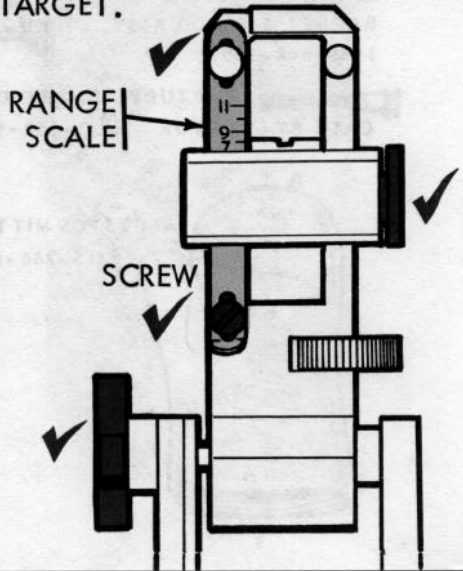



# HERE'S WHAT YOU

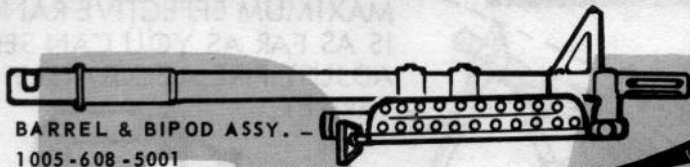

BARREL & BIPOD ASSY. -

1005-608-5001



RUPTURED CARTRIDGE

CASE EXTRACTOR - 4933-652-9950



SLING -

1005-714-9749

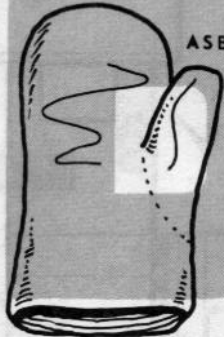

ASBESTOS MITTEN -

8415-266-8843

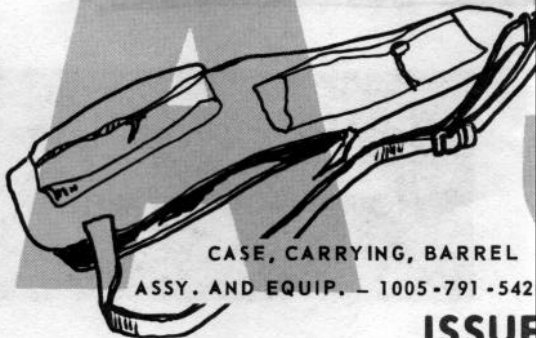

CASE, CARRYING, BARREL

ASSY. AND EQUIP. - 1005-791-542

## ISSUE

# BLANK FIRING ATTACHMENT

LIVE AMMO IS A **NO NO!**



CLAMPED AROUND  
FRONT LEG  
OF SIGHT

\*  
\* **TIGHT** \*  
\*

BLANKS  
ONLY!

MAKE SURE  
IT'S IN  
ALL THE WAY!



# Operating your M122 Tripod

*Where to find it*

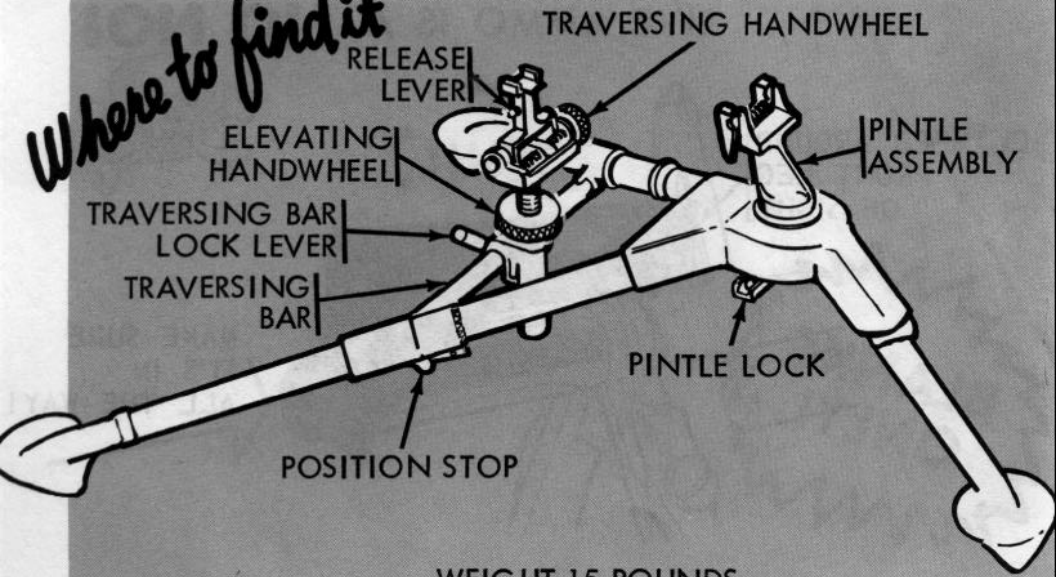

WEIGHT 15 POUNDS

# How to put the M60 on the Tripod

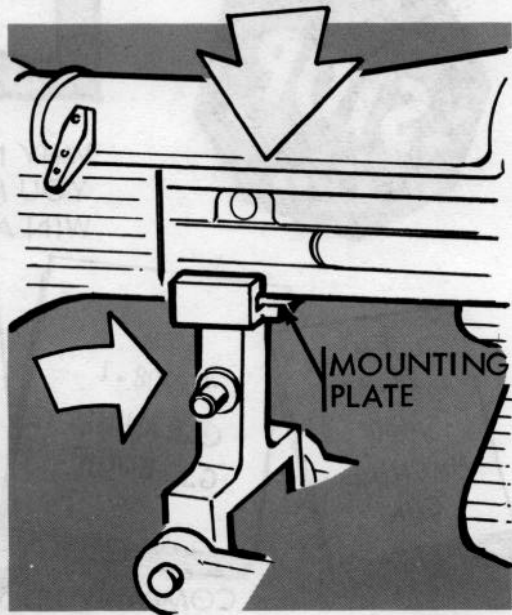
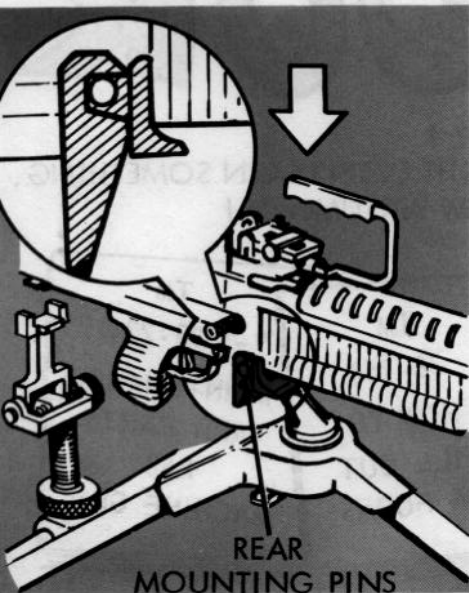



# LOOK

WHY NOT !  
YOU MIGHT EVEN LEARN SOMETHING .  
WIN A FEW ARGUMENTS !

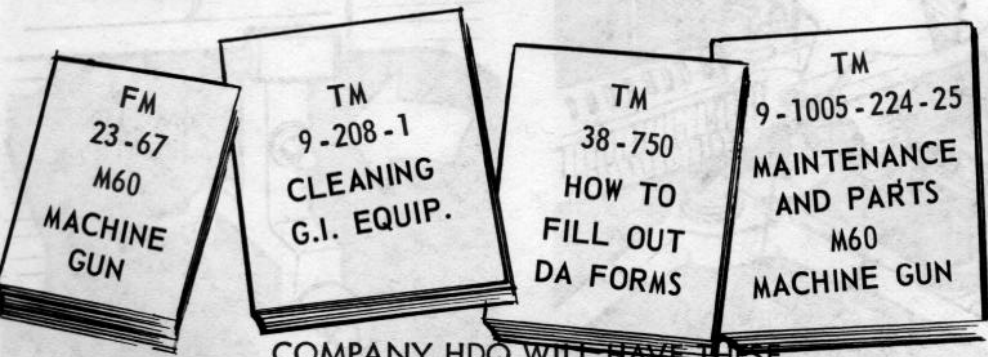

COMPANY HDQ WILL HAVE THESE.